

Submittal Sheet

VTX400C

Inline Centrifugal Fans

Standard Features

- Supplied with mounting bracket for easy installation
- Suitable for airstream temperatures up to 140°F
- Aerodynamic design allowing more air flow
- Heavy gage steel casing with a Hammertone powder coat finish, making it more sound absorbing, durable, impact resistant and rustproof
- ETL Listed
- High quality maintenance-free balanced motor, making it vibration free, quieter and longer lasting
- Extended collar and lip, allowing easy duct hook-up
- Optional speed control easing air flow adjustment, allowing better balancing of the ventilation system
- 10 year manufacturers warranty

Weight : 7.4 lbs. Metal Gauge : 18

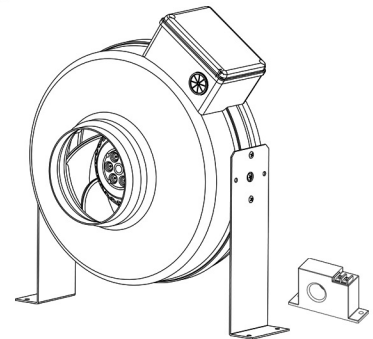
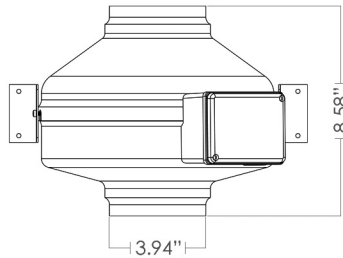
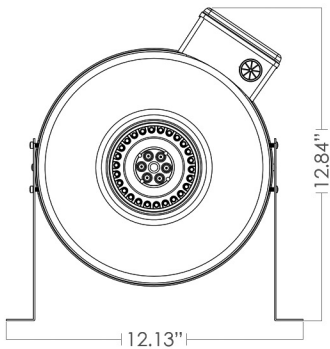

VTX400C Performance Data

Duct Dia.	RPM	Volts	Rated Watts	Max Amps	Static Pressure in Inches W.G.											Max Ps
					0"	0.125"	0.2"	0.25"	0.375"	0.5"	0.75"	1"	1.25"	1.5"	2"	
4"	2970	120	80	0,75	220	208	200	195	183	170	144	119	95	70	18	2.175"

Performance certified is for installation type D - Ducted inlet, Ducted outlet. Speed (RPM) shown is nominal. Performance is based on actual speed of test. Performance ratings include the effects of appurtenances (accessories) Inlet Duct, Inlet Bell, Outlet Duct

VTX400C Fan Specifications

Fan Tag	Qty	CFM	SP	Accessories	Remarks

Project _____ Submitted _____

Customer _____ Approved _____

Location _____